

# AV900-A PROJECTOR LIFT

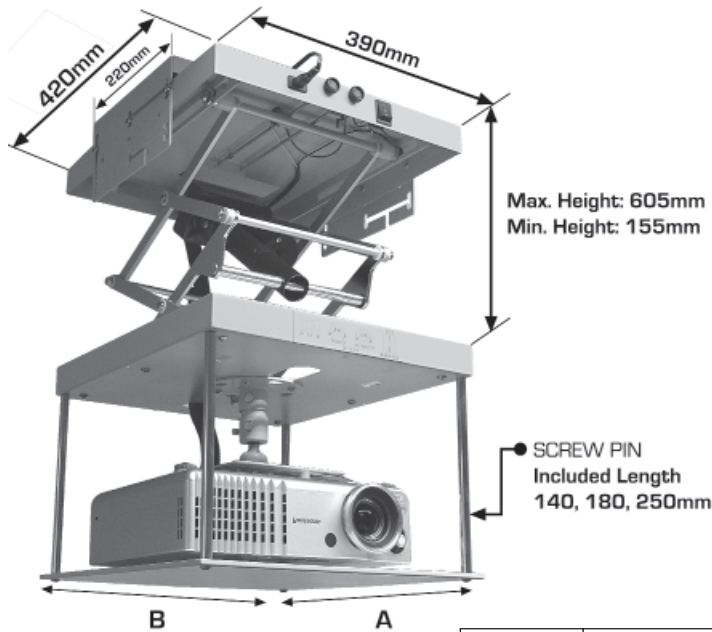

### TECHINICAL SPECIFICATIONS

- Rugged and durable design with all steel constructed
- Lifting load capacity up to 10kg
- Min compressed height (inside ceiling) is 295mm (with 140mm screw pin)
- Max extended height is 855mm (with 250mm screw pin)
- Conceal and integrated cable management for easy plug and play for projector, motorized screen, DVD player, computer
- Remote controller included
- Easy and quick dismantle for maintenance and servicing
- Easy adjustment for upper and lower limit for compressed and extended height

| A X B (mm) | Minimum Height (mm) | Maximum Height (mm) | Load Capacity | Motor Speed | Projector Size Up to (W x D x H)(mm) |
|------------|---------------------|---------------------|---------------|-------------|--------------------------------------|
| 430 x 400  | 295                 | 855                 | 10 KG         | 12.5mm/sec  | 360 x 340 x 250                      |

# AV900-B PROJECTOR LIFT

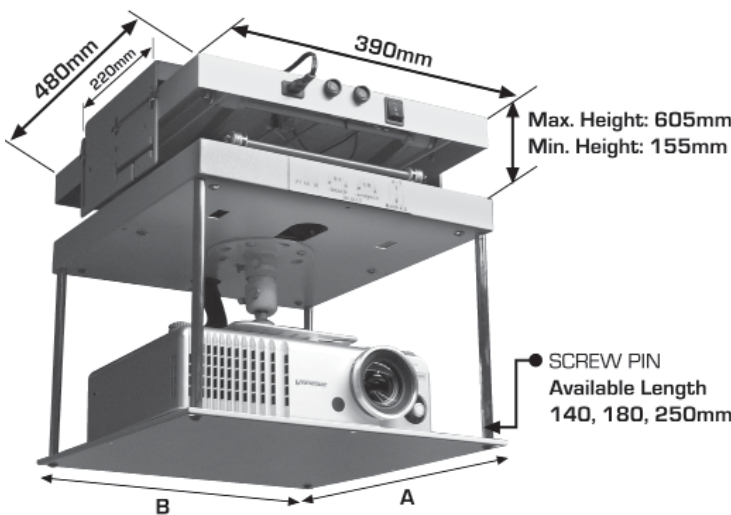

### TECHINICAL SPECIFICATIONS

- Rugged and durable design with all steel constructed
- Lifting load capacity up to 15kg
- Min compressed height (inside ceiling) is 295mm (with 140mm screw pin)
- Max extended height is 855mm (with 250mm screw pin)
- Conceal and integrated cable management for easy plug and play for projector, motorized screen, DVD player, computer
- Remote controller included
- Easy and quick dismantle for maintenance and servicing
- Easy adjustment for upper and lower limit for compressed and extended height

| A X B (mm) | Minimum Height (mm) | Maximum Height (mm) | Load Capacity | Motor Speed | Projector Size Up to (W x D x H)(mm) |
|------------|---------------------|---------------------|---------------|-------------|--------------------------------------|
| 500 x 420  | 295                 | 855                 | 15 KG         | 12.5mm/sec  | 440 x 320 x 250                      |

\* Specifications are subject to change without notice.

## AV900-C PROJECTOR LIFT

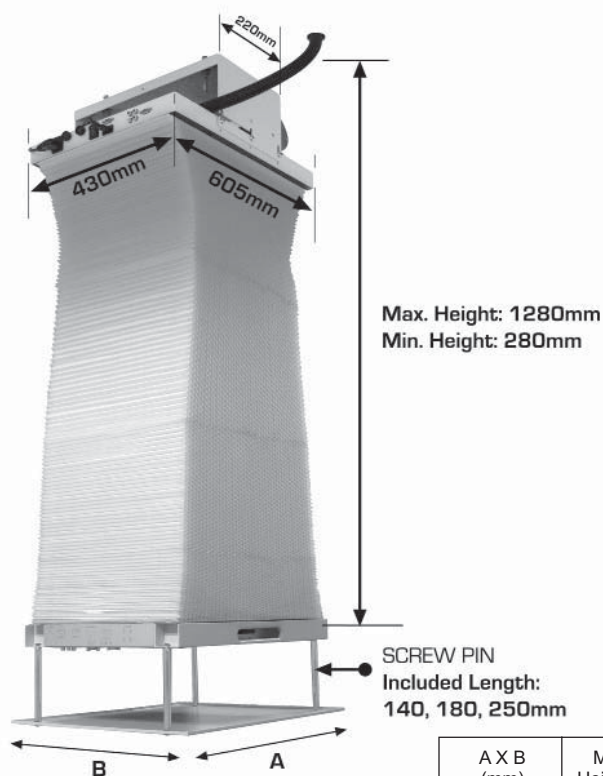

### TECHINICAL SPECIFICATIONS

- Rugged and durable design with all steel constructed
- Lifting load capacity up to 25kg
- Min compressed height (inside ceiling) is 420mm (with 140mm screw pin)
- Max extended height is 1530mm (with 250mm screw pin)
- Conceal and integrated cable management for easy plug and play for projector, motorized screen, DVD player, computer
- Remote controller included
- Easy and quick dismantle for maintenance and servicing
- Easy adjustment for upper and lower limit for compressed and extended height

| A X B (mm) | Minimum Height (mm) | Maximum Height (mm) | Load Capacity | Motor Speed | Projector Size Up to (W x D x H)(mm) |
|------------|---------------------|---------------------|---------------|-------------|--------------------------------------|
| 500 x 420  | 420                 | 1530                | 25 KG         | 20mm/sec    | 440 x 290 x 250                      |

## AV900-D PROJECTOR LIFT

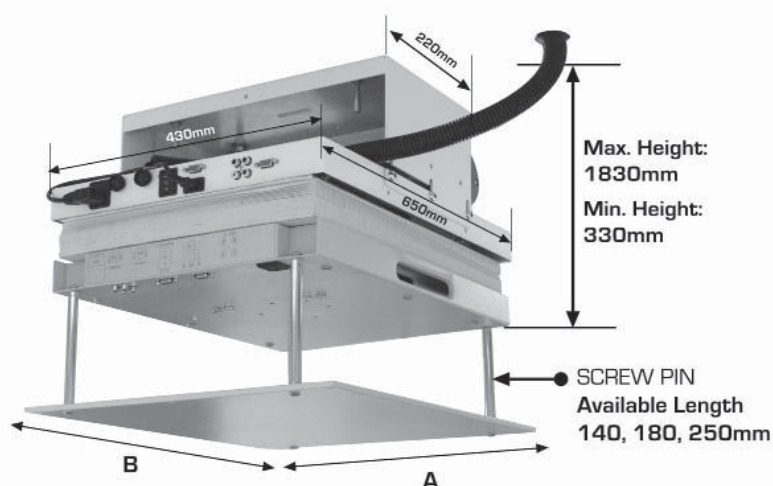

### TECHINICAL SPECIFICATIONS

- Rugged and durable design with all steel constructed
- Lifting load capacity up to 25kg
- Min compressed height (inside ceiling) is 470mm (with 140mm screw pin)
- Max extended height is 2080mm (with 250mm screw pin)
- Conceal and integrated cable management for easy plug and play for projector, motorized screen, DVD player, computer
- Remote controller included
- Easy and quick dismantle for maintenance and servicing
- Easy adjustment for upper and lower limit for compressed and extended height

| A X B (mm) | Minimum Height (mm) | Maximum Height (mm) | Load Capacity | Motor Speed | Projector Size Up to (W x D x H)(mm) |
|------------|---------------------|---------------------|---------------|-------------|--------------------------------------|
| 620 x 430  | 470                 | 2080                | 25 KG         | 20mm/sec    | 560 x 330 x 250                      |

\* Specifications are subject to change without notice.

## AV900-E HEAVY-DUTY PROJECTOR LIFT

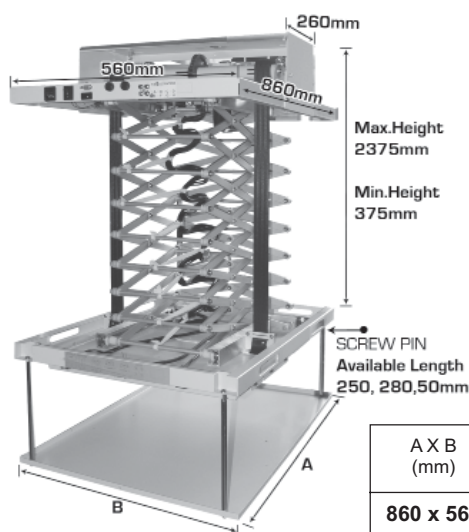

### TECHNICAL SPECIFICATIONS

- Rugged and durable design with all steel constructed
- Lifting load capacity up to 80kg
- Min compressed height (inside ceiling) is 625mm (with 250mm screw pin)
- Max extended height is 2705mm (with 280mm & 50mm screw pin)
- Conceal and integrated cable management for easy plug and play for projector, motorized screen, DVD player, computer
- Remote controller included
- Easy and quick dismantle for maintenance and servicing
- Easy adjustment for upper and lower limit for compressed and extended height

| A X B (mm) | Minimum Height (mm) | Maximum Height (mm) | Load Capacity | Motor Speed | Projector Size Up to (W x D x H)(mm) |
|------------|---------------------|---------------------|---------------|-------------|--------------------------------------|
| 860 x 560  | 625                 | 2705                | 80 KG         | 25 RPM      | 835 x 480 x 330                      |

## AV900-F HEAVY-DUTY PROJECTOR LIFT

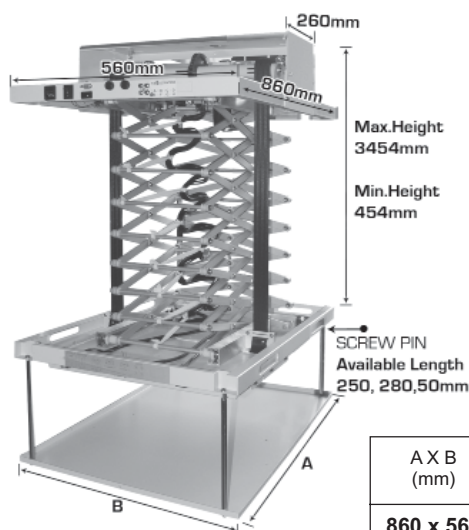

### TECHNICAL SPECIFICATIONS

- Rugged and durable design with all steel constructed
- Lifting load capacity up to 80kg
- Min compressed height (inside ceiling) is 704mm (with 250mm screw pin)
- Max extended height is 3784mm (with 280mm & 50mm screw pin)
- Conceal and integrated cable management for easy plug and play for projector, motorized screen, DVD player, computer
- Remote controller included
- Easy and quick dismantle for maintenance and servicing
- Easy adjustment for upper and lower limit for compressed and extended height

| A X B (mm) | Minimum Height (mm) | Maximum Height (mm) | Load Capacity | Motor Speed | Projector Size Up to (W x D x H)(mm) |
|------------|---------------------|---------------------|---------------|-------------|--------------------------------------|
| 860 x 560  | 704                 | 3784                | 80 KG         | 25 RPM      | 835 x 480 x 330                      |

## AV900-G HEAVY-DUTY PROJECTOR LIFT

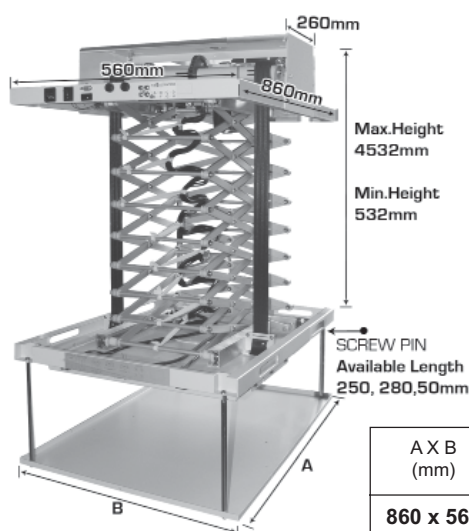

### TECHNICAL SPECIFICATIONS

- Rugged and durable design with all steel constructed
- Lifting load capacity up to 80kg
- Min compressed height (inside ceiling) is 782mm (with 250mm screw pin)
- Max extended height is 4862mm (with 280mm & 50mm screw pin)
- Conceal and integrated cable management for easy plug and play for projector, motorized screen, DVD player, computer
- Remote controller included
- Easy and quick dismantle for maintenance and servicing
- Easy adjustment for upper and lower limit for compressed and extended height

| A X B (mm) | Minimum Height (mm) | Maximum Height (mm) | Load Capacity | Motor Speed | Projector Size Up to (W x D x H)(mm) |
|------------|---------------------|---------------------|---------------|-------------|--------------------------------------|
| 860 x 560  | 782                 | 4862                | 80 KG         | 25 RPM      | 835 x 480 x 330                      |

# AV901

## LCD MONITOR LIFT

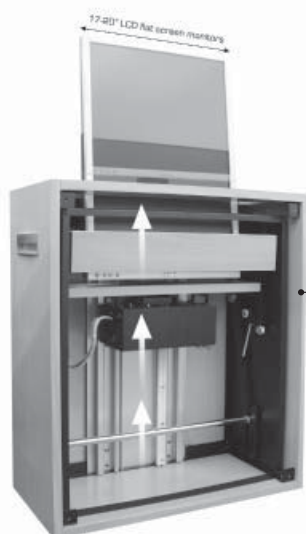

Exclude  
wooden  
case

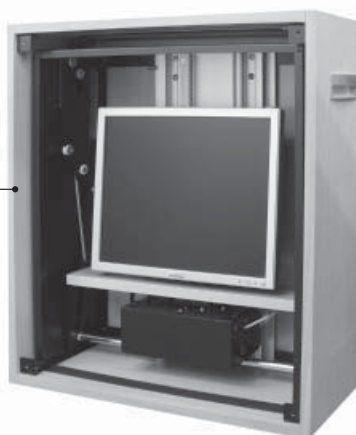

### DESCRIPTION

AV901 LCD Monitor Lift is created for customers with higher requirements of obscurity, silence, reliability & safety. Our opening mechanism is smooth and simple, allowing fully obscurity and lifting up of the monitor. It is ideal for most wide screen monitor of up to 20 inches.

### FEATURES

- Easy installation
- Conveniently pre-wired for fast hook-up
- Ergonomic 18 degree tilt angle for stress free viewing
- Lift & Tilt function is simply controlled by the four button switch panel, which is included in the package
- VESA 75x75, 100x100 for monitor mounting
- Special polymer built gear rack and guide wheels for silent operation
- Solid extruded light weight aluminum rack for rigidity



### 19" Monitor Lift

Installation Dimensions

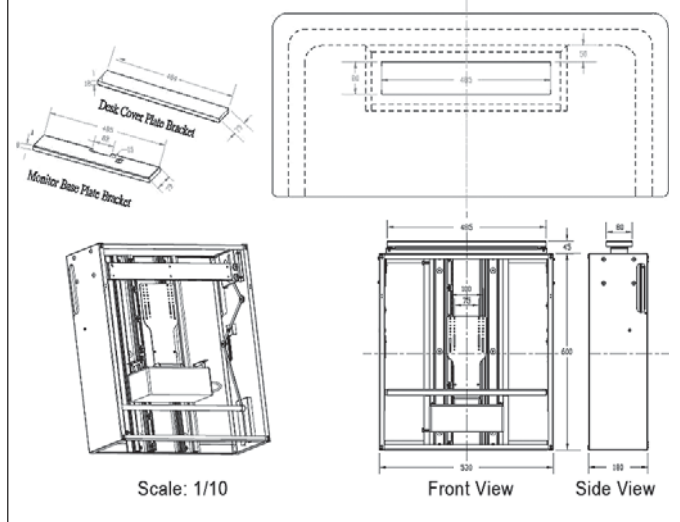

### TECHNICAL SPECIFICATION

|                           |  |
|---------------------------|--|
| <b>SUITABLE FOR:</b>      | 17-20" LCD flat screen monitors                                  |
| <b>MAX MONITOR SIZE:</b>  | mm: 484(W) x 320(H) x 70(D)<br>inches: 19" x 12"9/16 x 2"3/4     |
| <b>MONITOR MOUNTING:</b>  | 75 x 75mm and 100 x 100mm<br>Custom mounting brackets available  |
| <b>MONITOR BACK TILT:</b> | 0°+18  |
| <b>LIFT SPEED:</b>        | Open: 28 sec. Close: 28 sec. (max. travel)                       |
| <b>SOUND LEVEL:</b>       | up : 42.2db avg., down 42.8db avg                                |
| <b>LIFT CAPACITY:</b>     | 20Kg [45 lbs]  |
| <b>VOLTAGE:</b>           | 100-240V AC 50/60Hz  |
| <b>POWER CONSUMPTION:</b> | 19 watts   |
| <b>DIMENSIONS:</b>        | mm: 530(W) x 600(H) x 180(D)<br>inches: 20"7/8 x 23"5/8 x 7"1/16 |
| <b>WEIGHT:</b>            | 11Kg [24 lbs]  |
| <b>LIFT TRAVEL:</b>       | 500mm max. infinitely adjustable                                 |
| <b>CONTROL:</b>           | 5V DC analog. Four button control panel included                 |
| <b>COLOR:</b>             | Black, other colors available upon request                       |

\* Specifications are subject to change without notice.