

# AV815M

## PROJECTOR MOUNTING PLATE

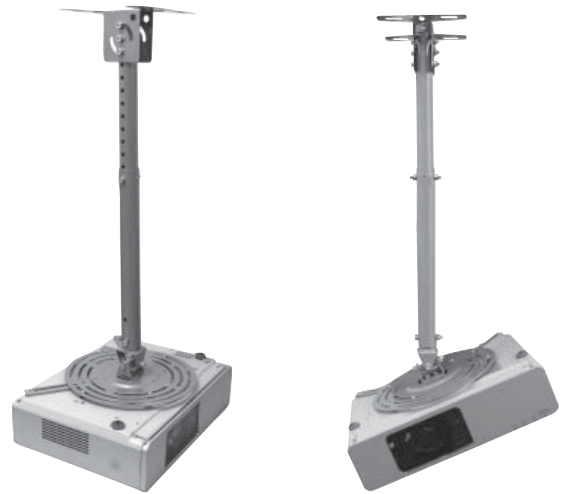

### DESCRIPTION

This features 2 different length of extension arms that allows flexible positioning to **PANASONIC PT-F100, PT-F200, PT-F300** projector mounting point. With these extensions, arms position around lamp and filter have easy access/maintenance to maximize lamp life. With spacers provided, the mount is able to adapt to projector base, no matter how oddly shaped, to maintain a level installation.

### FEATURES

- Fast and easy installation
- Designed for medium size projector
- To be used combination with AV815 Projector Ceiling Mount
- Quick release universal mount for Projector
- 60 degrees Rotate for Projector
- +/- 20 degrees Tilt and Roll for Projector
- Cable management

### TECHNICAL SPECIFICATION

**SUITABLE PROJECTOR:** PANASONIC PT-F100, PT-F200, PT-F300

**HEIGHT ADJUSTMENT:** Max: 817mm or Min: 567mm

**LOAD CAPACITY:** 20kg (44 lbs)

**COLOR OPTION:** Silver

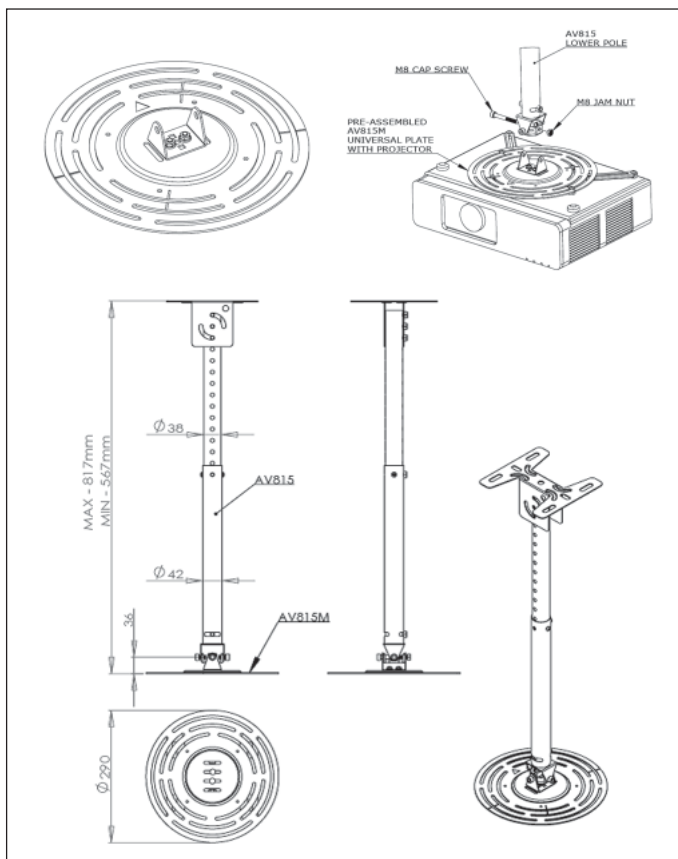

\* Specifications are subject to change without notice.