

## AV900-C PROJECTOR LIFT

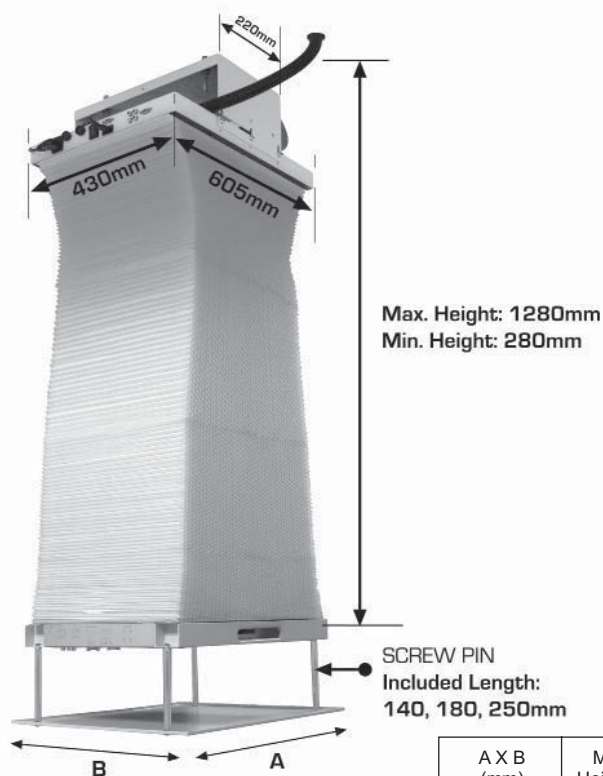

### TECHINICAL SPECIFICATIONS

- Rugged and durable design with all steel constructed
- Lifting load capacity up to 25kg
- Min compressed height (inside ceiling) is 420mm (with 140mm screw pin)
- Max extended height is 1530mm (with 250mm screw pin)
- Conceal and integrated cable management for easy plug and play for projector, motorized screen, DVD player, computer
- Remote controller included
- Easy and quick dismantle for maintenance and servicing
- Easy adjustment for upper and lower limit for compressed and extended height

A X B (mm)	Minimum Height (mm)	Maximum Height (mm)	Load Capacity	Motor Speed	Projector Size Up to (W x D x H)(mm)
500 x 420	420	1530	25 KG	20mm/sec	440 x 290 x 250

## AV900-D PROJECTOR LIFT

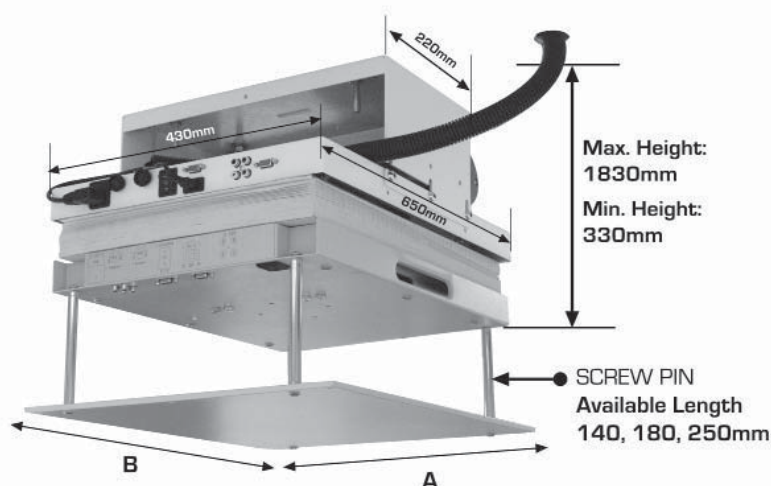

### TECHINICAL SPECIFICATIONS

- Rugged and durable design with all steel constructed
- Lifting load capacity up to 25kg
- Min compressed height (inside ceiling) is 470mm (with 140mm screw pin)
- Max extended height is 2080mm (with 250mm screw pin)
- Conceal and integrated cable management for easy plug and play for projector, motorized screen, DVD player, computer
- Remote controller included
- Easy and quick dismantle for maintenance and servicing
- Easy adjustment for upper and lower limit for compressed and extended height

A X B (mm)	Minimum Height (mm)	Maximum Height (mm)	Load Capacity	Motor Speed	Projector Size Up to (W x D x H)(mm)
620 x 430	470	2080	25 KG	20mm/sec	560 x 330 x 250

\* Specifications are subject to change without notice.