

Projector Ceiling Mount



Model: **AV815**

User Operation Guide

IMPORTANT NOTES



- Thank you for purchasing the Universal Projector Ceiling Mount. This bracket is suitable for about most of projectors up to a load fro 15kg (33 lbs)
- To ensure correct usage, please read this instruction manual thoroughly. Keep this manual for future reference.
- BRACKETS SHOULD BE MOUNTED ONLY BY A QUALIFIED INSTALLER.
- User will be responsible for any injuries and damages tat may arise from improper installation and handing of Universal Ceiling Mounting Kit.
- Ensure all mounting screws are appropriately positioned and properly tightned/ fastened.
- Installers are to ensure customer's safety during installtion.
- We reserve the right to amend or undertake any necessary changes without prior notice.

WARNING

This symbol indicates the incorrect handling. Ignoring this symbol can result in the possibility of personal injury or even death.

CAUTION

This symbol indicates the incorrect handling. Ignoring this symbol can result in the possibility of personal injury and physical damage.

 Caution (general)	This symbol indicates additional cautions (including warnings).
 Forbidden (general)	This symbol indicates forbidden actions.
 Required (general)	This symbol indicates required actions.

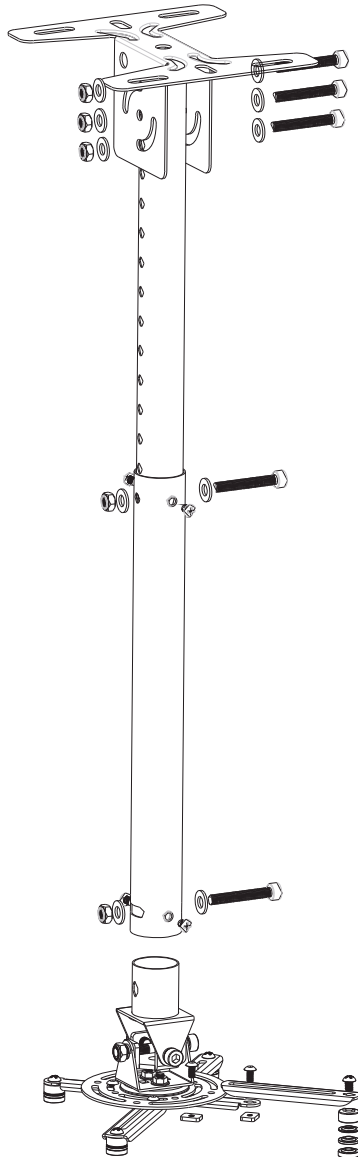
PARTS SPECIFICATIONS

User Operation Guide

WAR

Assembling without the correct use bolts and screws at designated points may result in injury and damage to properties or the unit collapsing from its installed position.

Should a malfunction occur disconnect the power from the main socket and surround the area with ropes to prevent others from getting near it.

Check and ensure the ceiling where you install can support the weight of the projector and ceiling mounting.

All Ceiling Mounting Brackets are to be firmly secured so the unit will not drop off its installed position.

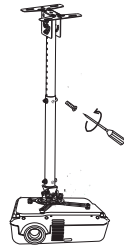

Steps should be taken to ensure the ceiling and installed unit can withstand external forces like earthquakes, vibrations, etc.

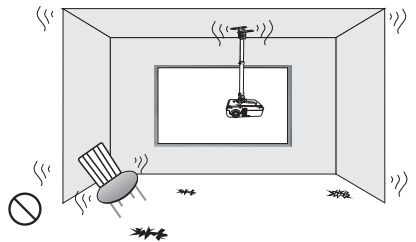

Do not remove any bolts and screws from the Ceiling Mounting Brackets or do any changes to the Ceiling Mounting Brackets.

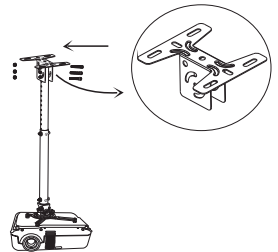

Do not install near an air-conditioner.

Do not install at place where there are excessive dust and smoke as fire could arise from these sources.

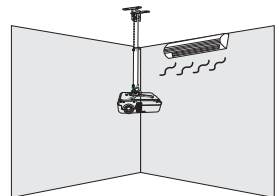

WARNING

Keep the room well ventilated to prevent room temperature rising and possibilities resulting in fire.

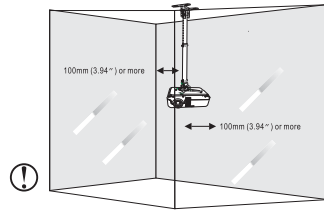

Do not install in location where room temperature and humidity are excessively high to prevent fire.
To prevent fire, avoid contact with water

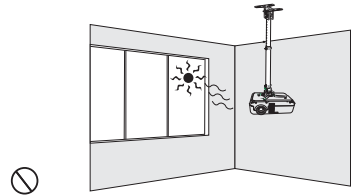

Do not apply unnecessary stress or load on the installed unit.

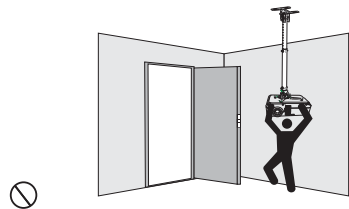

PACKAGE CONTENTS

1. Each package should contain the parts listed and shown below

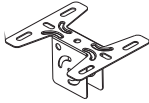

Ceiling Mounting plate..... 1 pc

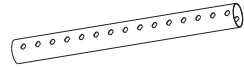

Upper Rod..... 1 pc

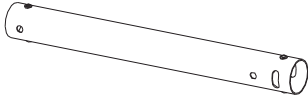

Lower Rod..... 1 pc

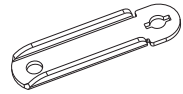

Short Extension Bracket 1
50mm 1 pc

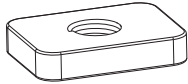

Square nut..... 4 pcs

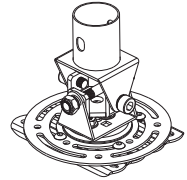

Universal Head
Assembly..... 1 pc



Truss Head Screw
M2.6x15/ M3x15/M3x20 4pcs
M4x15/M4x20/M4x25 4pcs
M6x15/M6x20/M6x25 4pcs
M6x5 4pcs



Washer 1mm... 4 pcs
Washer 2mm... 4 pcs
Washer 4mm... 4 pcs

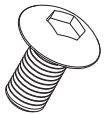

Socket Button Screw
M5x10..... 4 pcs

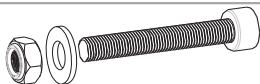

Socket cap Screw/Lock Nut/Washer
M8x55 5pcs
M8 Lock Nut 5pcs
Φ8 x 1.6MM Washer 10pcs

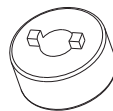

Bottom Spacer
..... 1 pc

INSTALLATION GUIDE

1. Assembly procedure-Installation of Suspension Rod

1.1 Install upper rod

Install the upper rod using M8x55 Socket Cap Screw and M8 Self-Locking Nylon Nut, Ceiling Mounting Plate

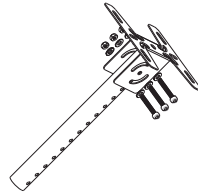

1.2 Install low rod

First align two holes on the lower rod at the suitable holes on the upper rod, tighten them with M8x55 Socket Cap Screw and M8 Self-Locking Nylon Nut.

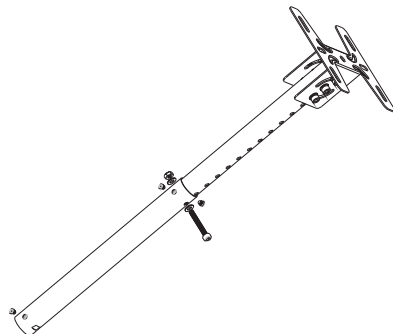

INSTALLATION GUIDE

2. Parts Assembly - Installation of Universal Base

2.1

Lift the Projector with both middle finger along the depth of the Projector to search for the Central of Gravity (CG).

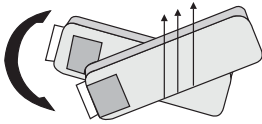

2.2

Lift the Projector with both middle finger along the depth of the Projector to search for the Central of gravity (CG).

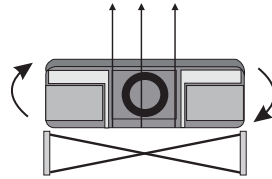

2.3

When the CG Point (Depth of Projector) and (Width of Projector) intersection meet, that will be the assume CG of Projector

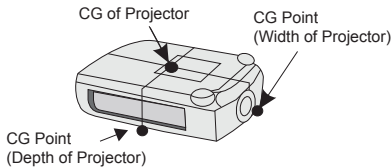

2.4

Locate the Projector CG position and determine screw size for mounting the Projector by placing the Universal head Assembly near to the Projector CG found in step-2.3.

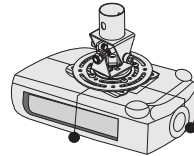

2.5

Loosen and slide the Extension Brackets on the Universal Head Assembly and align them to the Projector mounting holes.

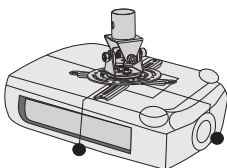

2.6

Select the suitable Extension Bracket from the package. There are 2 size available as shown. There are also 3 types of combination.

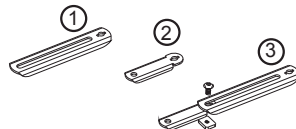

INSTALLATION GUIDE

2.7

Assemble the selected Extension Bracket with the following items: Bottom Spacer, Spacer (if needed) & Square Nut.

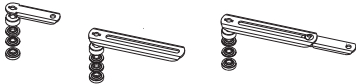

2.8

Use the Tress head screws provided in the package to tighten the Extension Brackets to the Projector.

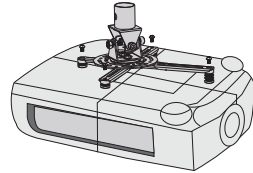

2.9

Lift up the Projector to check the CG of the assembled Projector and tighten all the screws once confirmed. The assembly is then completed.

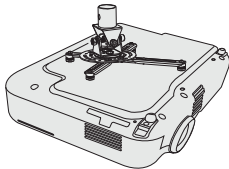

INSTALLATION GUIDE

3. Installation of Universal Ceiling Mounting Kit

3.1

Install the Universal Ceiling Mounting Kit to the ceiling. Fix Suspension Rod by M10 expansion bolt (not included) on the ceiling. Refer to drawing.

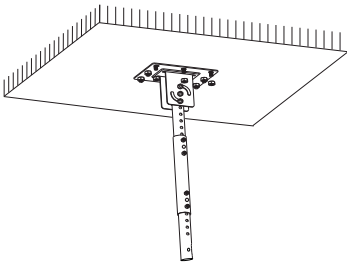

3.2

Install the Universal Base Plate with the projector (B) using M8x55 Socket Cap Screw and M8 Self-locking Nylon Nut, to joint A and B together.

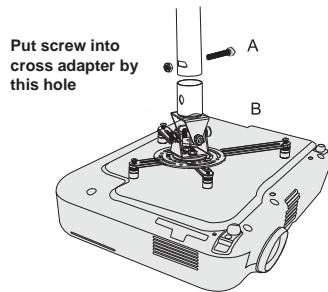

3.3

Installation completed.

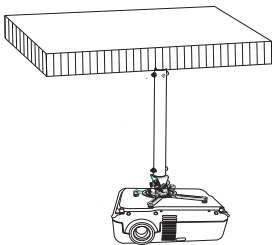

* Please consult our authorized service person when you meet any trouble in installation. We are not liable for any damage or injury caused by mishandling or improper operation.

SPECIFICATION

Gross Weight : 2.9kg (2.7 lbs)

Gross Dimension : 420 x 200 x 120 mm | 16.5" x 8" x 5" inch

**Lexextendable Length
with Optional Rod** : (7900) mm Ø 38mm & Ø 42mm

Load Capacity : 15kg (33 lbs)

** For details and updated Command and Program Software, please visit and download from www.abtussingapore.com

**Specifications are subject to changes without notice.*

