

Projector Flush Ceiling Mount



Model: **AV817**

Revision 0

User Operation Guide

IMPORTANT NOTES



- Thank you for purchasing the Universal Projector Flush Mount. This bracket is suitable for about 80%-90% of projector up to a load of 15kg (33lbs)
- To ensure correct usage, please read this instruction manual thoroughly. Keep this manual for future reference.
- BRACKETS SHOULD BE MOUNTED ONLY BY A QUALIFIED INSTALLER.
- User will be responsible for any injuries and damages that may arise from improper installation and handling of Universal Ceiling Mounting Kit.
- Ensure all mounting screws are appropriately positioned and properly tightened/ fastened.
- Installers are to ensure customer's safety during installation.
- We reserve the right to amend or undertake any necessary changes without prior notice.

WARNING

This symbol indicates the incorrect handling. Ignoring this symbol can result in the possibility of personal injury or even death.

CAUTION

This symbol indicates the incorrect handling. Ignoring this symbol can result in the possibility of personal injury and physical damage.

 Caution (general)	This symbol indicates additional cautions (including warnings).
 Forbidden (general)	This symbol indicates forbidden actions.
 Required (general)	This symbol indicates required actions.

PARTS SPECIFICATIONS

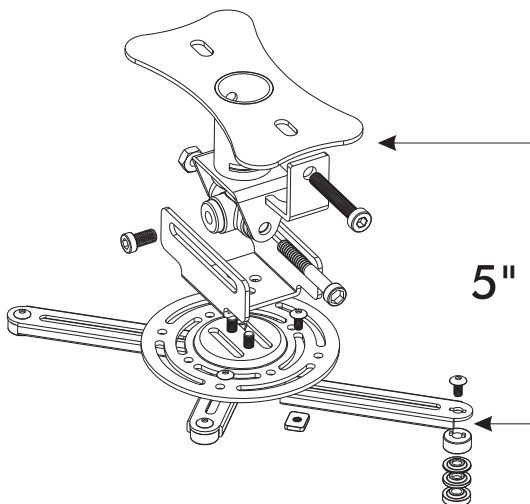

WARNING

Assembling without the correct use bolts and screws at designated points may result in injury and damage to properties or the unit collapsing from its installed position.

Should a malfunction occur disconnect the power from the main socket and surround the area with ropes to prevent others from getting near it.

Check and ensure the ceiling where you install can support the weight of the projector and ceiling mounting.

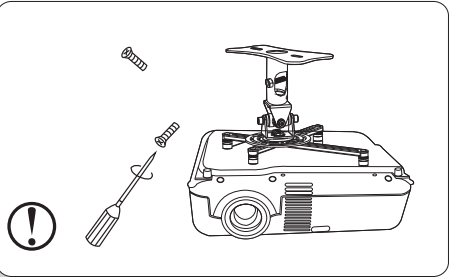

Steps should be taken to ensure the ceiling and installed unit can withstand external forces like earthquakes, vibrations, etc.

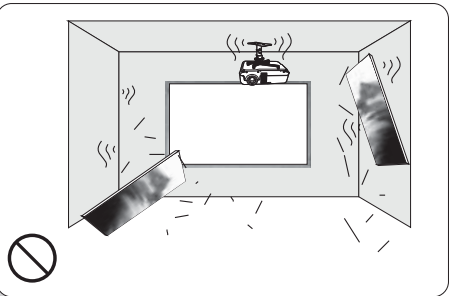

All Ceiling Mounting Brackets are to be firmly secured so that unit will not drop off its installed position.

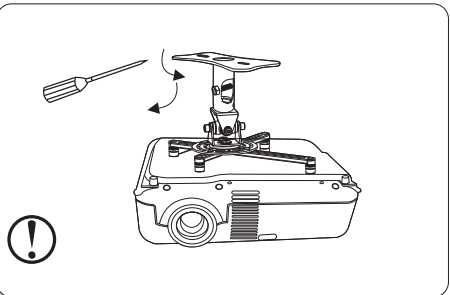

Do not removed any bolts and screws from Ceiling Mounting Brackets or do any changes to the Ceiling Mounting Brackets.

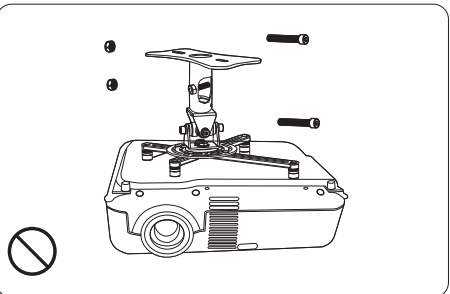

User Operation Guide

CAUTION

Do not install near to air-conditioner.

Do not install at place where there are excessive dust and smoke as fire could arise from these sources.

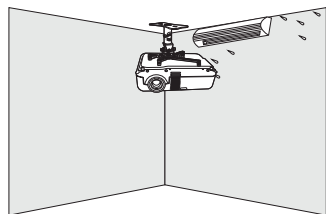

Keep the room well ventilated to prevent room temperature rising and possibilities resulting in fire.

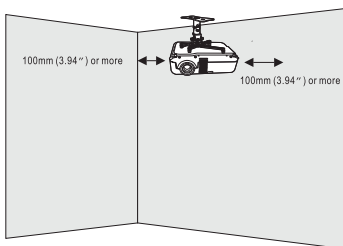

Do not install in location where room temperature and humidity are excessively high to prevent fire.

To prevent fire, avoid contact with water.

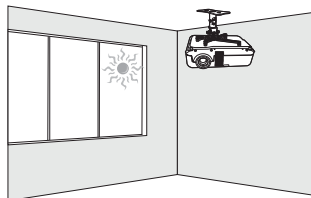

Do not apply unnecessary stress or load on the installed unit.

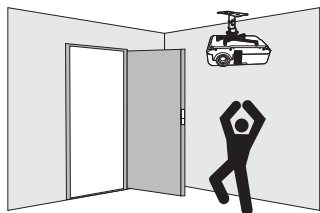

PACKAGE CONTENTS

1. Each package should contain the parts listed and shown below

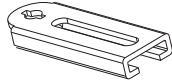

Part 1

Extension Bracket

75mm..... 2pcs

150mm..... 2pcs



Part 2

Truss head Screw

M2.6x15/M3x15/M3x20..... 4pcs

M4x15/M4x20/M4x25..... 4pcs

M5x15/M5x20/M5x25..... 4pcs

M6x15/M6x20/M6x25..... 4pcs



Part 3

Bottom Spacer..... 4pcs

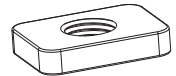

Part 4

Square Nut..... 4pcs



Part 5

Socket Bottom Cap Screw

M5x10..... 4pcs

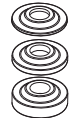

Part 6

Washer

1mm 4pcs

2mm 4pcs

4mm 4pcs



Part 7

Allan Key

Φ 3 1pc

Φ 6 1pc

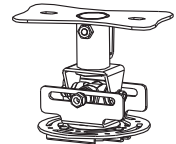

Part 8

817 Flush Ceiling Mount

User Operation Guide

INSTALLATION GUIDE

1. Parts Assembly - Installation of Universal Base

1.1

Lift the Projector with both middle finger along the depth of the Projector to search for the Central of Gravity (CG).

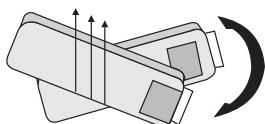

1.2

Lift the Projector with both middle finger along the depth of the Projector to search for the Central of gravity (CG).

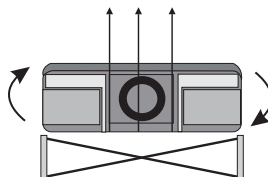

1.3

When the CG Point (Depth of Projector) and (Width of Projector) intersection meet, that will be the assume CG of Projector

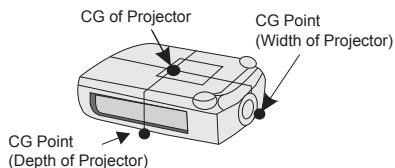

1.4

Remove M8 Hexigan Nut and M8x50 Socket Screw from Part-8 as shown below.

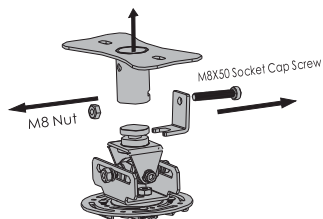

1.5

Locate the Projector CG position and determine screw size for mounting the Projector by placing the Universal Head Assembly near to the Projector CG found in step-1.3

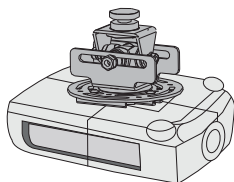

1.6

Loosen and slide the Extension Brackets on the Universal Head Assembly and align them to the Projector mounting holes

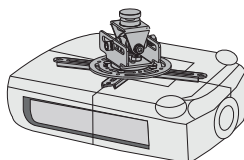

INSTALLATION GUIDE

1.7

Change to a shorter or longer Extension Brackets provided in the package if needed. There are 2 sizes available as shown.

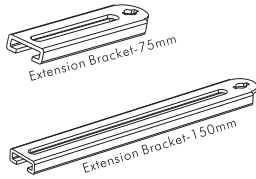

1.8

Assemble the selected Extension Bracket with the following items: Bottom Spacer, Spacer (if needed) & Square Nut.

* For Extension Bracket more than 50mm (1.97") (Square Nut x 2)

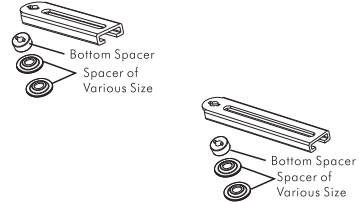

1.9

Use the Tress head screws provided in the package to tighten the Extension Brackets to the Projector.

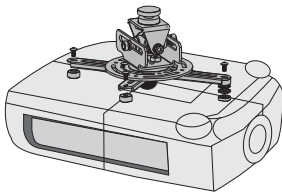

2.0

Lift up the Projector to check the CG of the assembled Projector and tighten all the screws once confirmed.

The assembly is then completed.

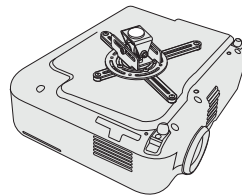

INSTALLATION

2. Installation of Universal Ceiling Mounting Kit

2.1

Install the Ceiling plate to the ceiling by M8 bolt (not included) into the ceiling. Refer to diagram

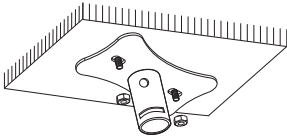

2.2

Lift and insert the assembled Projector done in step 2.0 into the lower Rod of the Universal Ceiling Mounting Kit. Insert the Locking Hook into the cutting slot and tighten them with M8x50 Socket and Self-locking nut.

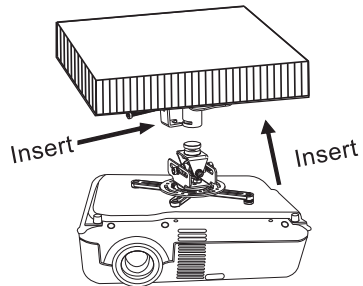

2.3

Installation completed.

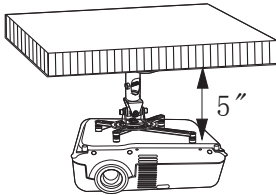

*** Please consult our authorized service person when you meet any trouble in installation. We are not liable for any damage or injury caused by mishandling or improper operation.**

NOTE: Do consult a qualified and authorized service technician if you encounter any technical difficulties. We are not liable for any damage or injuries arising from any improper installation or mishandling.

ABtUS
S I N G A P O R E