

INSTALLATION

Step-9 — insert the sub-assembly done in Step-8 into the AV815 upper pole which has been installed on the ceiling (not shown, refer to AV815 User manual for instruction). Run and connect all cables. Pan, tilt and align the Projector to the screen.

Step-10 — slide and insert the Main cage onto the Top Bracket assembly.

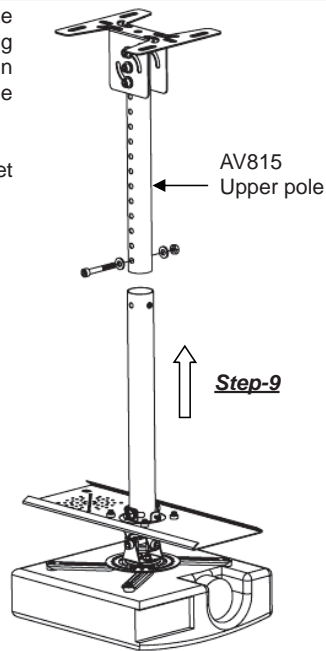
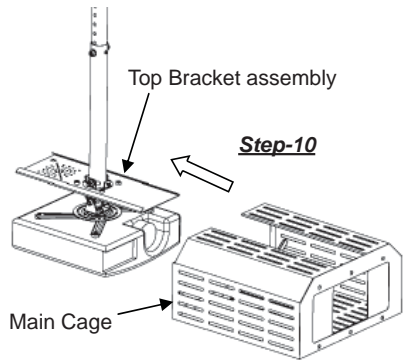

Step-11 — slide and insert the Back Panel into the back of Main cage

Step-12 — lock the cage

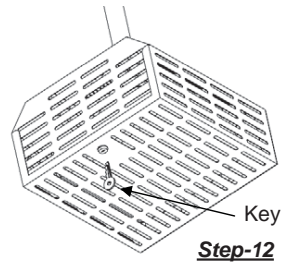
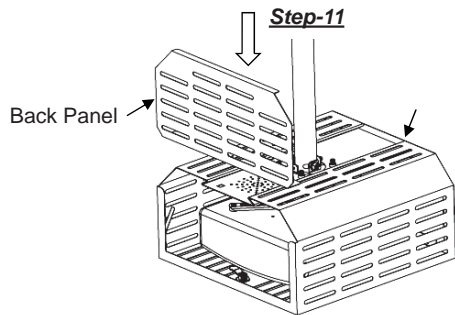

Projector Cage





** For details and updated Command and Program Software, please visit and download from www.abtussingapore.com

*Specifications are subject to changes without notice.

Model: AV820

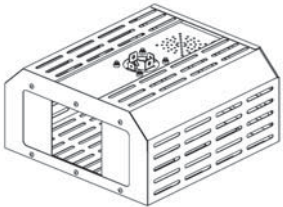
PACKAGING CONTENT

	 <p>1x 1x 2x 2x 1x 1x</p>
<p>Item-1 AV820 Projector Cage - 1 set</p>	<p>Item-2 Screw Bag - 1 set</p>

INSTALLATION

- Step-1** — unlock the Back Panel by using the Key provided (in Item-2).
- Step-2** — lift and slide the Back Panel out of the Main Cage.
- Step-3** — slide the Top Bracket assembly out of the Main Cage.

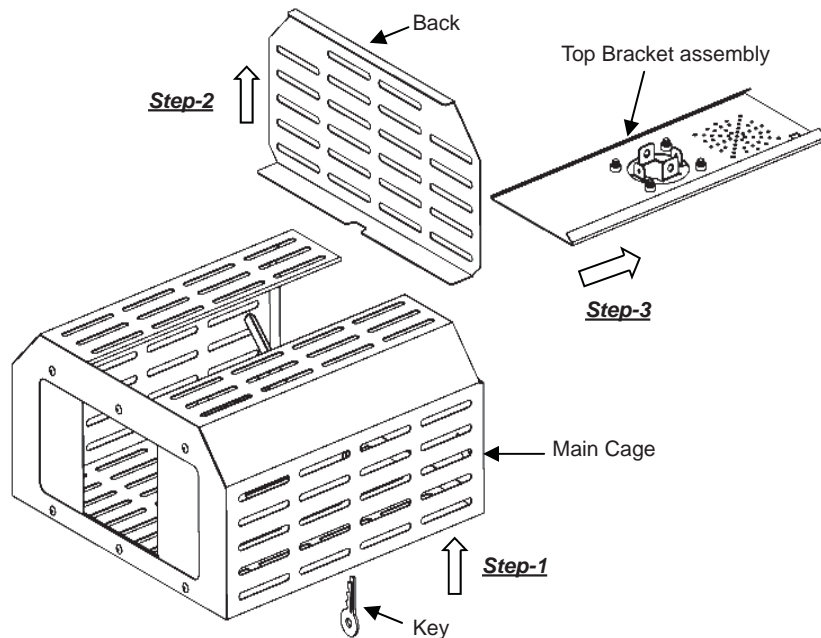

INSTALLATION

- Step-4** — fix AV815 Universal head onto Projector (refer to AV815 User Manual for instruction).
- Step-5** — insert Top Bracket assembly into short pipe of AV815 Universal head.
- Step-6** — slide the Top Bracket assembly out of the Main Cage.

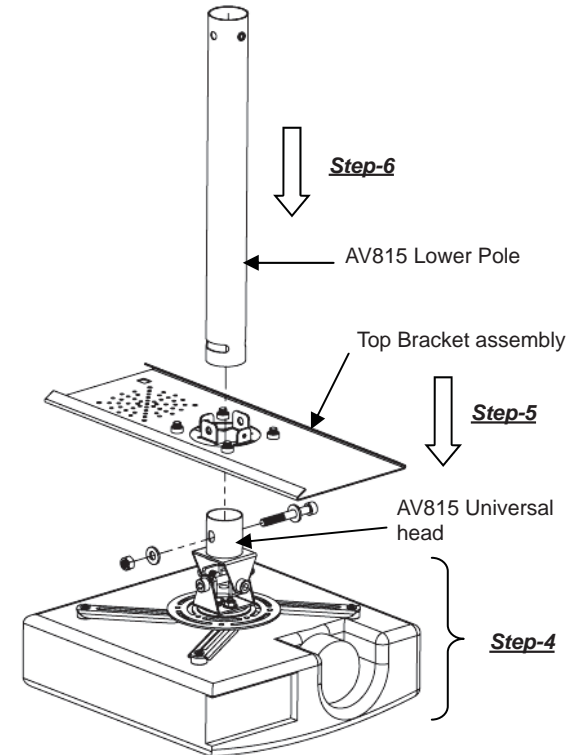

- Step-7** — secure with M8X65 cap screw, washers and nylock nut (in Item-2)
- Step-8** — fix 2x M4 cross pan head screws (in Item-2) for balancing.

